

Product Code

1417E/2S05

Solenoid Valve CO2
1/4"ODS Seat 05 w/o Coil
PS = 130 bar

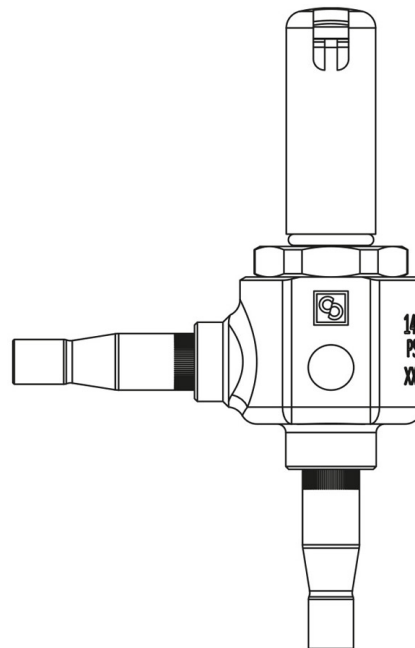

Product use

Accessories for use with refrigerant R744.
These valves are exclusively sold in the model without coil (S suffix).

Product details

Operating principle Direct acting

Coil Type (1) HF3

Connections ODS Ø [in.] 1/4"

Connections ODS Ø [mm] -

Kv [m³/h] 0,065

PS [bar] 130

MWP [psi] (4) 1885

TS [°C] min. -40

TS [°C] max. +150

Package Pcs. 17

Notes

- (1) : coils that can be fit on the valves
- (2) : for use on the oil line TS = -10 /+70 °C

(3) : for use on the oil line please contact CASTEL

(4): UL approval ongoing