

## Product Code

# 6110E/X02

Receiver Valve CO2

PS=140bar  
PS = 140 bar

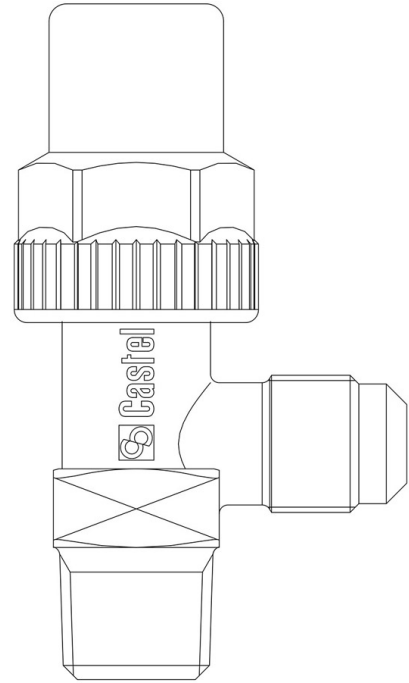

## Product use

Accessories for use with refrigerant R744.

## Product Details

Connections SAE Flare 1/4"

Connections SAE Flare 1/4"

NPT -

NPT -

Kv [m<sup>3</sup>/h] 0,44

PS [bar] 140

MWP [psi] (3) 2030

TS [°C] min. -40

TS [°C] max. +130

Package pcs 90

## Notes where expressly stated

(1): including a conical gasket 7580/2

(2): can be installed without gasket

(3): according to UL approval